

2010
MAGAZINE FOR
DECORATION
PASSIONATES

LA MOULURE

WWW.ORACDECOR.COM

ISSUE

02

INTERNATIONAL
PROJECTS

**MARLIES
DEKKERS**
AMSTERDAM

SOFITEL
BRUSSELS

& MORE CREATIVITY

A PAINTER'S DREAM

**DESIGN
COVING**
INTERVIEW CARL LALOO

SKIRTING BOARDS
INDIRECT LIGHTING

ORAC[®]
DECOR

MARLIES DEKKERS

AMSTERDAM THE NETHERLANDS



1
GIVE YOUR INTERIOR
A LUXURIOUS,
FRIVOLOUS
LOOK WITH THE
ORAC DECOR
MOULDINGS

- 01 D200
- 02 P9010
- 03 C352
- 04 D310
- 05 P9010F
- 06 SX118
- 07 P9010
- 08 D402
- 09 D401

DE
Luxuriös und frivol
mit Leisten von
ORAC DECOR.

FR
Luxe et frivolité avec
des moulures ORAC
DECOR.

NL
Lingerie passen
wordt vanaf nu
echte luxe met ORAC
DECOR.



- 10 D101
- 11 P9010
- 12 P8020F
- 13 P8030F

HOTEL SOFITEL

BRUSSELS BELGIUM



2
**TRIPLE
CORNICING
CREATES
TOP-LEVEL
INDIRECT LIGHTING**



- 01 C322
- 02 C332
- 03 C333
- 04 C217

DE
Dreifache Eckleisten
bringen indirekte
Beleuchtung auf
Topniveau.

FR
Des triples corniches
pour un éclairage
indirect de haut
niveau.

NL
Driedubbele
kroonlijsten brengen
indirecte verlichting
op topniveau.



- 05 C217
- 06 C333
- 07 C322
- 08 C332
- 09 C333
- 10 C322
- 11 C332
- 12 C333

THE WAGRAM SHOP

KNOKKE BELGIUM



3
**EXCLUSIVE
CREATIONS
WITH
TIMELESS
COMBINATIONS**

- 01 CX107
- 02 PX103
- 03 CX107
- 04 PX103
- 05 SX118

DE
Exklusive Kreationen
durch zeitlose
Kombinationen.

FR
Créations
exclusives pour
des combinaisons
intemporelles.

NL
Exclusieve creaties
met tijdloze
combinaties.

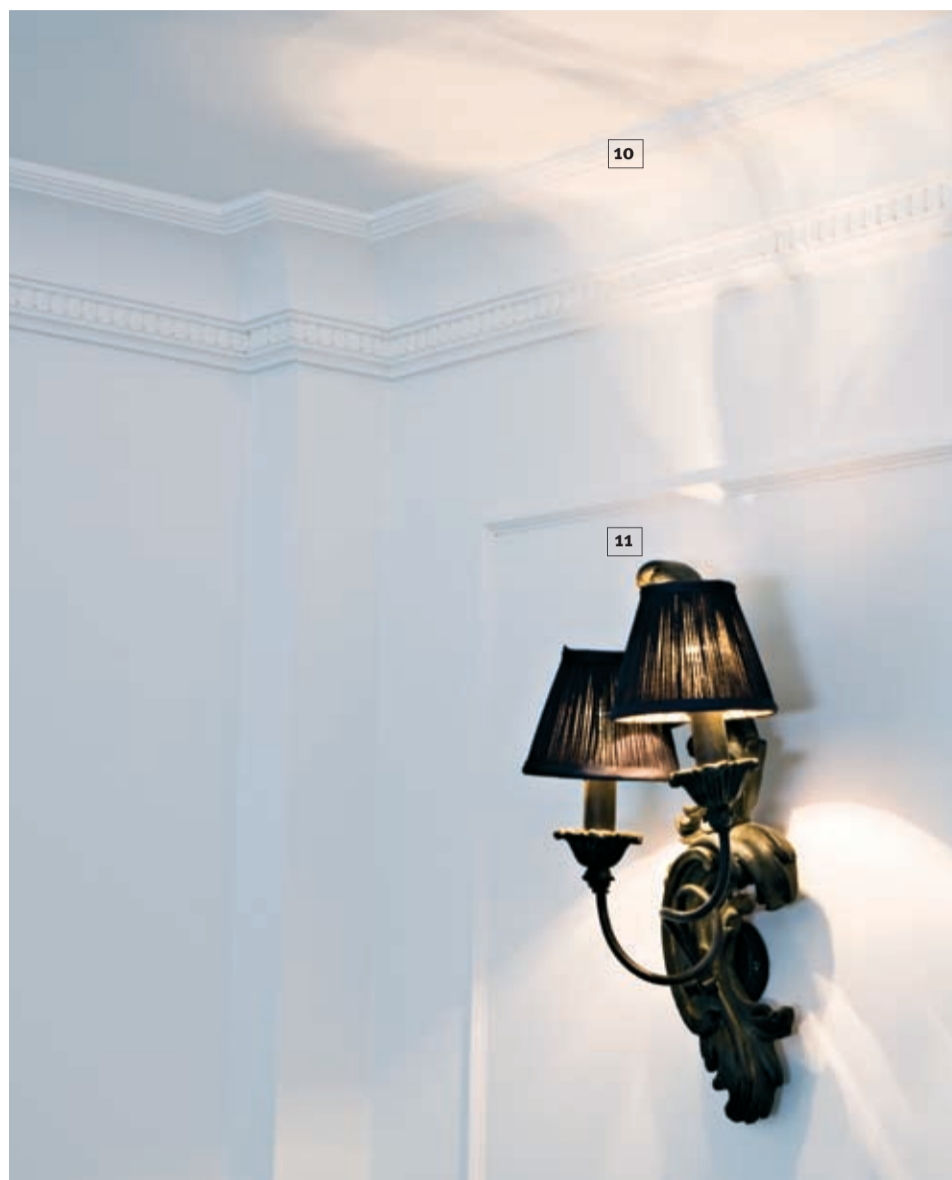

- 06 CX107
- 07 PX103
- 08 DX119
- 09 SX118
- 10 CX107
- 11 PX103
- 12 PX103
- 13 SX118
- 14 CX107
- 15 PX103
- 16 DX119

METIENDO VIVENDUM

HEVER BELGIUM



4
COMBINE
AND **CREATE**
TO MAKE A
UNIQUE
ATMOSPHERE

- 01 PX117
- 02 PX113
- 03 PX103
- 04 D62
- 05 SX118

DE
Kombinieren und
kreieren für eine
einzigartige
Atmosphäre.

FR
Combinez et créez
pour une ambiance
unique.

NL
Combineer en creëer
originele blikvangers
voor een unieke
sfeer.



- 06 D140
- 07 P8020F
- 08 P4020
- 09 P4020F
- 10 SX118F
- 11 D120
- 12 PX113
- 13 D140
- 14 DX119

CHATEAU MONT ROYAL

CHANTILLY FRANCE



- 01 P8030
- 02 DX121
- 03 P8030
- 04 SX118
- 05 CX124
- 06 C322
- 07 P8030
- 08 P8030F
- 09 R08
- 10 R08
- 11 P8030F
- 12 P8030

DE
Lassen Sie sich von
der reiche Kollektion
von ORAC DECOR
inspirieren.

FR
Inspirez-vous de
la collection royale
d'ORAC DECOR.

NL
Inspireer je door de
royale collectie van
ORAC DECOR.



- 13 C200
- 14 K3112
- 15 K3102
- 16 P8030
- 17 PX103

- 18 P9010
- 19 M9010L
- 20 M9010B
- 21 P8030F
- 22 P9020F
- 23 SX118F

- 24 C322
- 25 P8020
- 26 P8030
- 27 SX118

HOTEL THE BLACK

ANTWERP BELGIUM

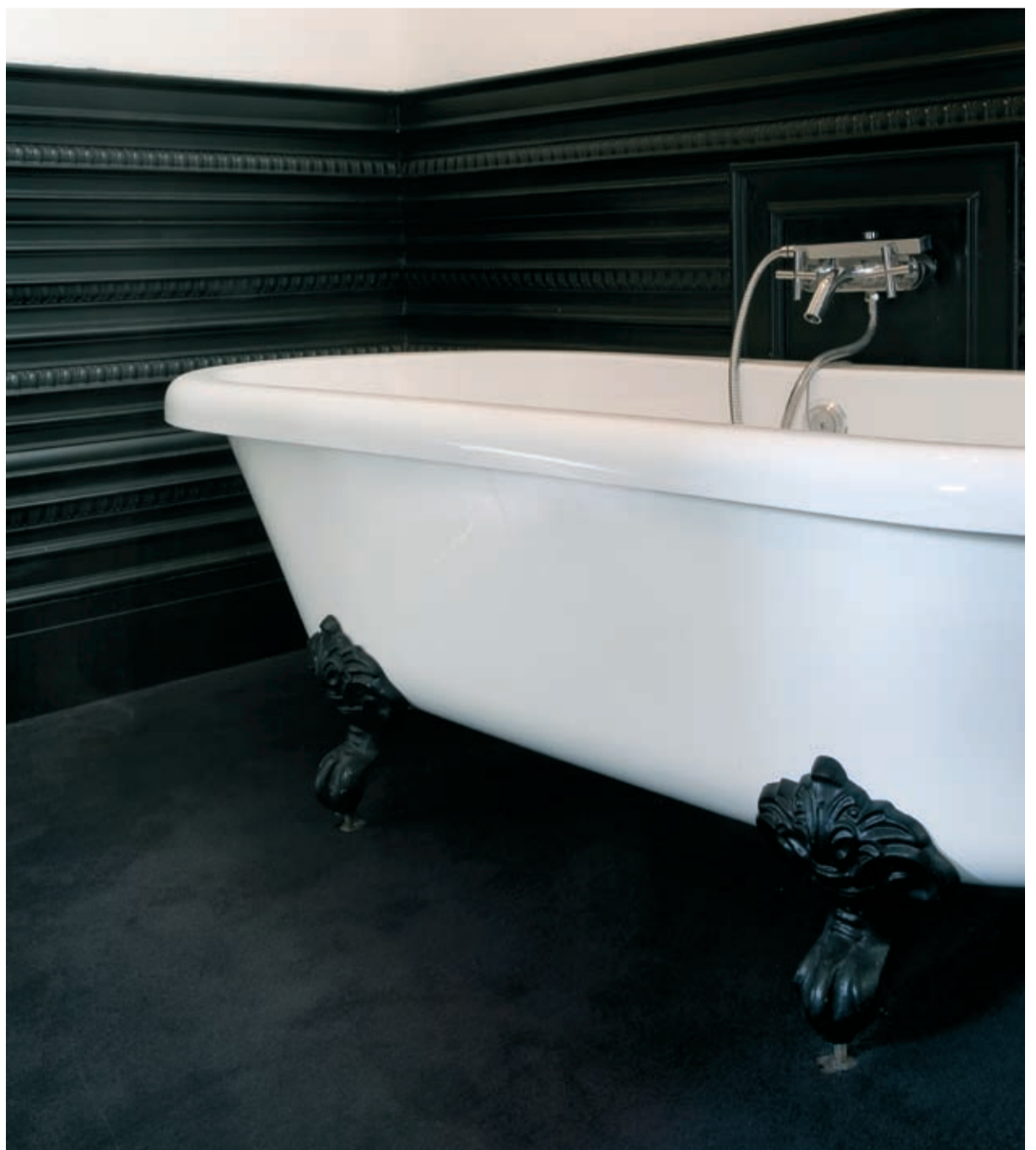

DE
Tauchen Sie ein in die geheimnisvolle Welt von Schwarz, Weiß und verführerischen Profilen.

FR
Plongez dans l'univers mystérieux du noir et blanc et des profils séduisants.

NL
Duik onder in de mysterieuze wereld van zwart-wit en verleidelijke profielen.



6
DIP INTO THE MYSTERIOUS WORLD OF BLACK & WHITE PROFILES

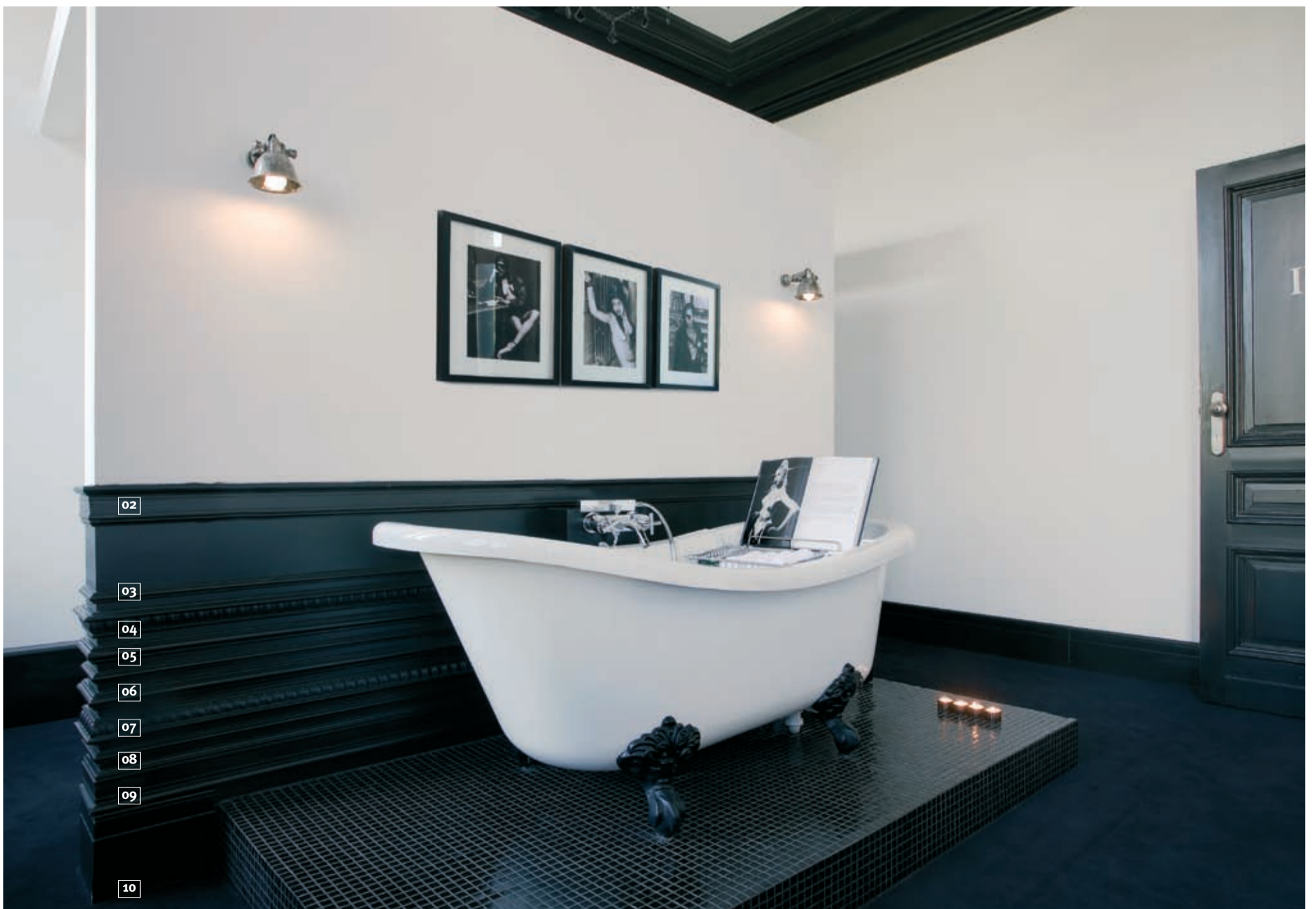

- 01 SX156
- 02 DX121
- 03 PX103
- 04 PX114
- 05 PX120
- 06 DX119
- 07 PX114
- 08 PX103
- 09 DX121
- 10 SX156

INDEX REFERENCES

ORAC DECOR PRODUCTS



Marlies Dekkers
by Marlies Dekkers

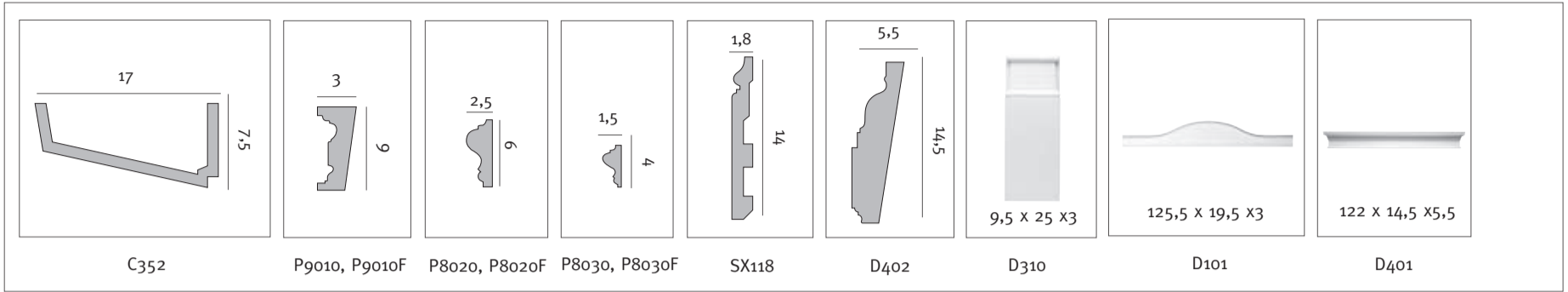

Sofitel
by Pinto & Co

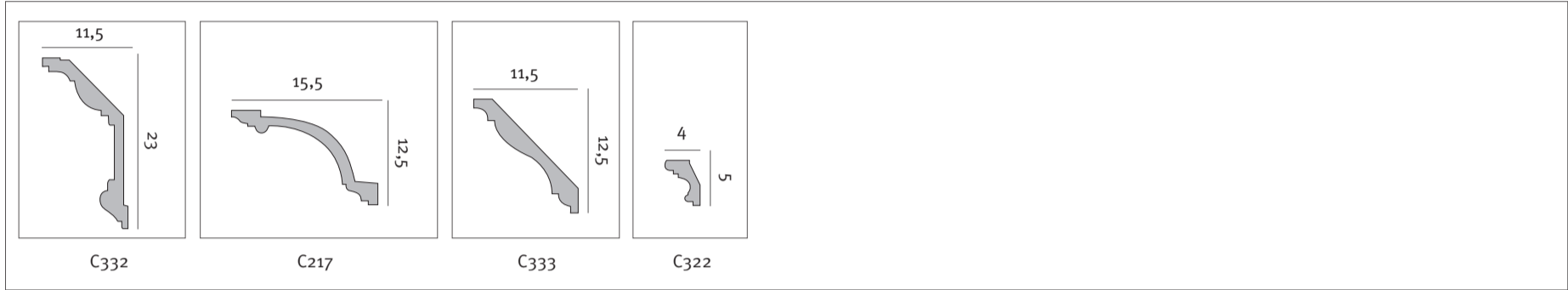

Wagram
by Alain De Bree

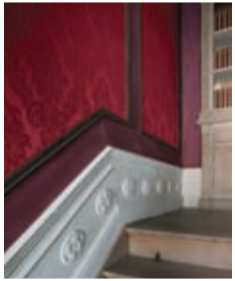
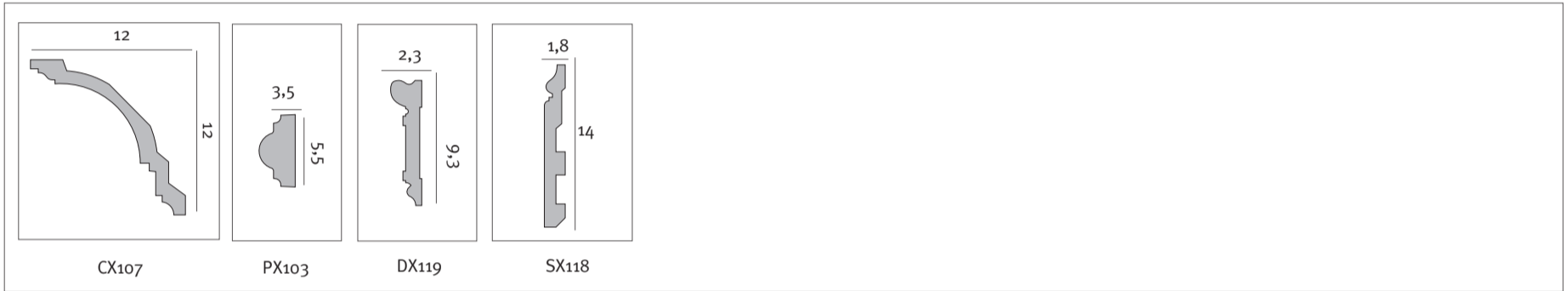

Metiend Vivendum
by Sigisbert Engelbosh

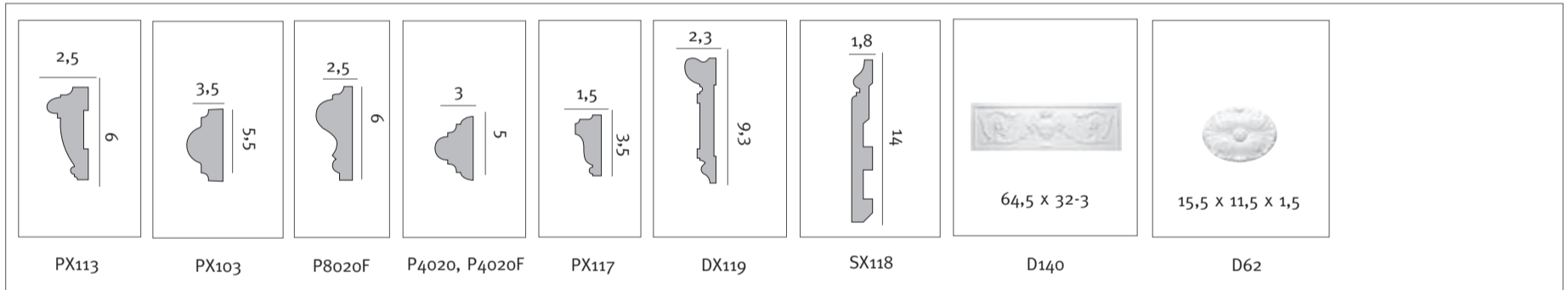

Hotel Mont Royal
by Pilar Paiva de Sousa

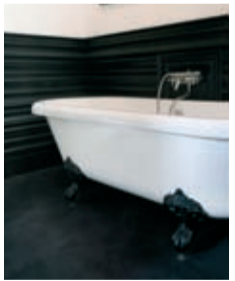
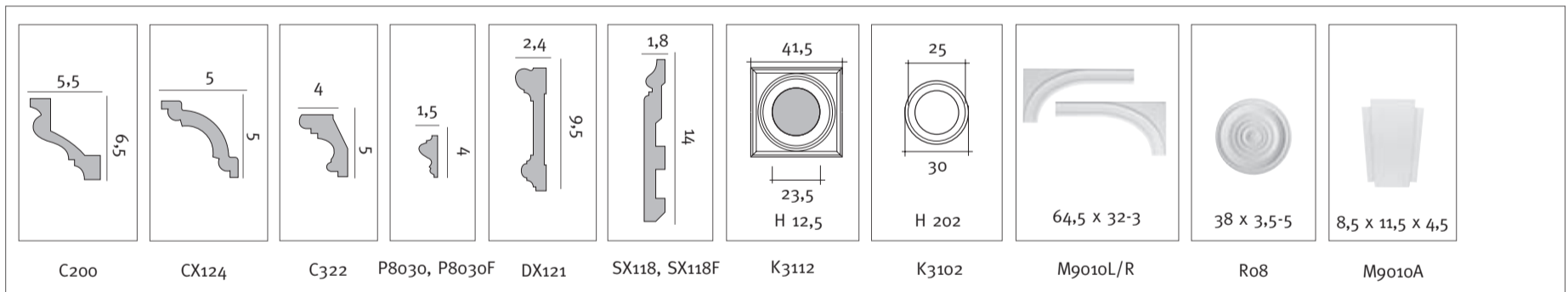

Hotel The Black
by Kim Soeffers

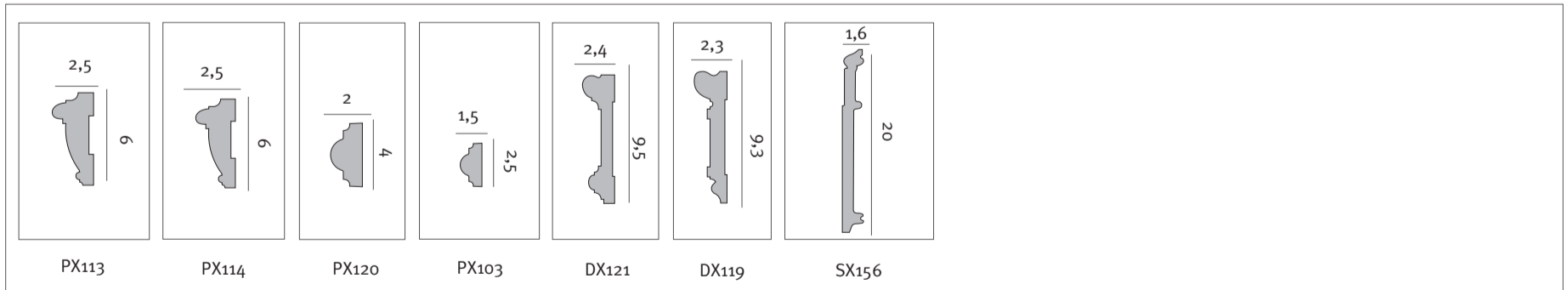

Modular
by Rotor

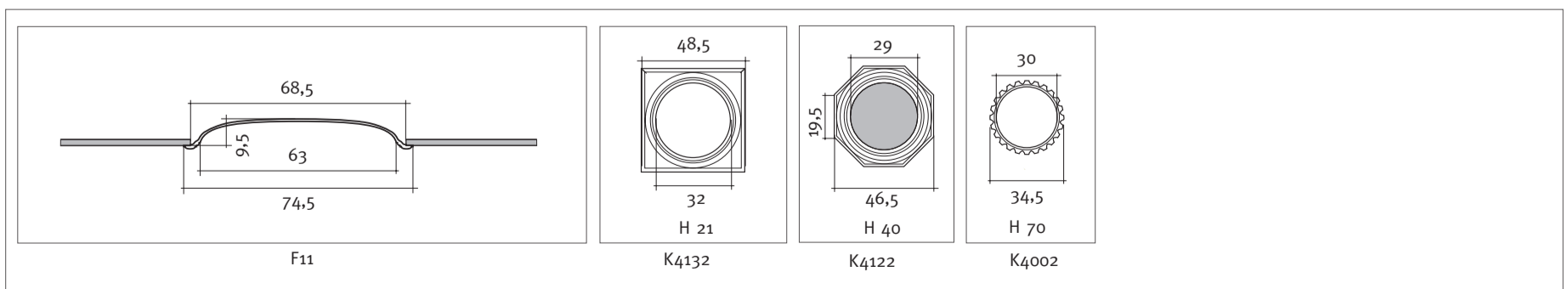

DIMENSIONS IN CM



Queen of Light

Salvation since 1980

EXHIBITIONS
SNAPSHOTS
ORAC PROJECTS





INTERNATIONAL SNAPSHOTS

ORAC PROJECTS



1 2

1 - 2
Project: Disco Nikita
Place: Telgate - Bergamo, Italy
Architect: Fabrizio Roncarolo

3 - 4
Project: Jack's Casino
Place: Helmond, the Netherlands
Design: Odico Interieurbouw, Deurne
Installation: Stukadoorsbedrijf
G. Verberne, Ommel



3



4



5



7



6

5 - 6 - 7
 Project: Swiss Tiara
 Place: the Netherlands
 Installation: Da Capo
 Scheepstimmerbedrijf,
 Hardinxveld-Giessendam

8
 Project: Paon Royal
 Place: ZOO, Antwerp, Belgium
 Architect: Kurt Hereygers



8

9
 Project: Ballroom Hotel Caro
 Place: Bucharest, Roumania



9

PRODUCT FOCUS

CONTEMPORARY COVINGS

INTERVIEW CARL LALOO



**'What a discovery:
contemporary
AND functional
Orac Decor covings'**

'After growing up surrounded by my father's paint pots and training as an advertising illustrator, at the age of seventeen I started work as a painter.'

'About ten years ago, I discovered the wonderful world of coving. What a discovery! Not only do you get rid of the 'biscuit tin effect', but coving is also a great way of hiding cables (photo 'before'). And with a little creativity, you can get a lot more out of it too: from making a frame round a flatscreen TV, to a chalkboard in the kitchen. You can really play around with coving and give your interior a contemporary makeover.'

DE

'Nachdem ich zwischen den Farbkübeln meines Vaters aufgewachsen bin und eine Ausbildung als Reklamemaler gemacht habe, habe ich mit 17 begonnen, als Maler zu arbeiten.'

'Vor ungefähr zehn Jahren habe ich die unglaubliche Welt der Profile entdeckt. Eine echte Innovation! Man nimmt nicht nur den Schachteffekt weg, Profile sind auch ausgesprochen praktisch, um Kabel abzudecken (photo 'before').

Und mit etwas Kreativität ist noch viel mehr möglich: von einem Rahmen rund um einen Flatscreen bis hin zu einer Tafel in der Küche.

Mit Profilen kann man spielen und ein Interieur modern aufwerten.'

FR

'Après avoir grandi au milieu des pots de peinture de mon père et suivi une formation en tant que peintre publicitaire, je me suis lancé à l'âge de 17 ans dans le métier de peintre.'

'Il y a une dizaine d'années environ, j'ai découvert l'univers magique des moulures. Une innovation! Les moulures permettent non seulement de faire disparaître l'effet de 'boîte à biscuits' mais sont en outre très pratiques pour camoufler des câbles (foto 'before').

Et moyennant un brin de créativité, vous pouvez les utiliser pour une multitude d'autres applications: encadrement autour d'un écran plat ou tableau noir dans la cuisine par exemple. Avec les moulures, vous pouvez jouer à l'infini et revaloriser votre intérieur en lui apportant une touche contemporaine.'

NE

'Na op te groeien tussen de verfpotten van mijn vader en een opleiding als reclameschilder, stapte ik als 17-jarige in het vak van schilder.'

Zo'n tien jaar geleden ontdekte ik de wondere wereld van moulures. Een innovatie! Je haalt niet alleen het 'koekendooseffect' weg, moulures zijn ook uiterst handig om kabels te verbergen (foto 'before').

Met een beetje creativiteit haal je er nog meer uit: van een kader rond een flatscreen tot een krijtbord in de keuken. Met moulures kan je spelen en een interieur eigentijds opwaarderen.'

De Orac Decor moulures zijn bovendien reeds geprimed (voorgeschilderd) en de naadjes zijn gemakkelijk weg te werken met de speciale nadenlijm Extra Fix en de juiste tools.

Kortom, de ORAC moulures geven een absolute meerwaarde aan het interieur.

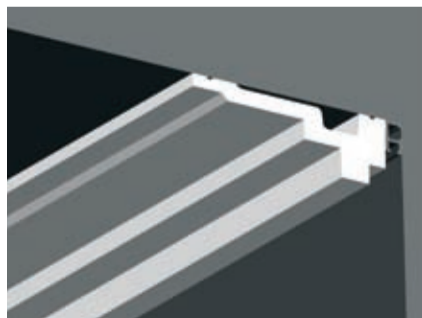

Contemporary Orac Decor covings in combination with rail-systems for frames.

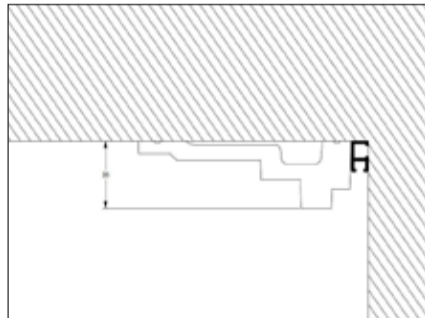

More info on mouldings & Rail-systems on www.artiteq.nl



after

PRODUCT FOCUS

CONTEMPORARY

CORNICES KROONLIJSTEN ECKLEISTEN CORNICHES

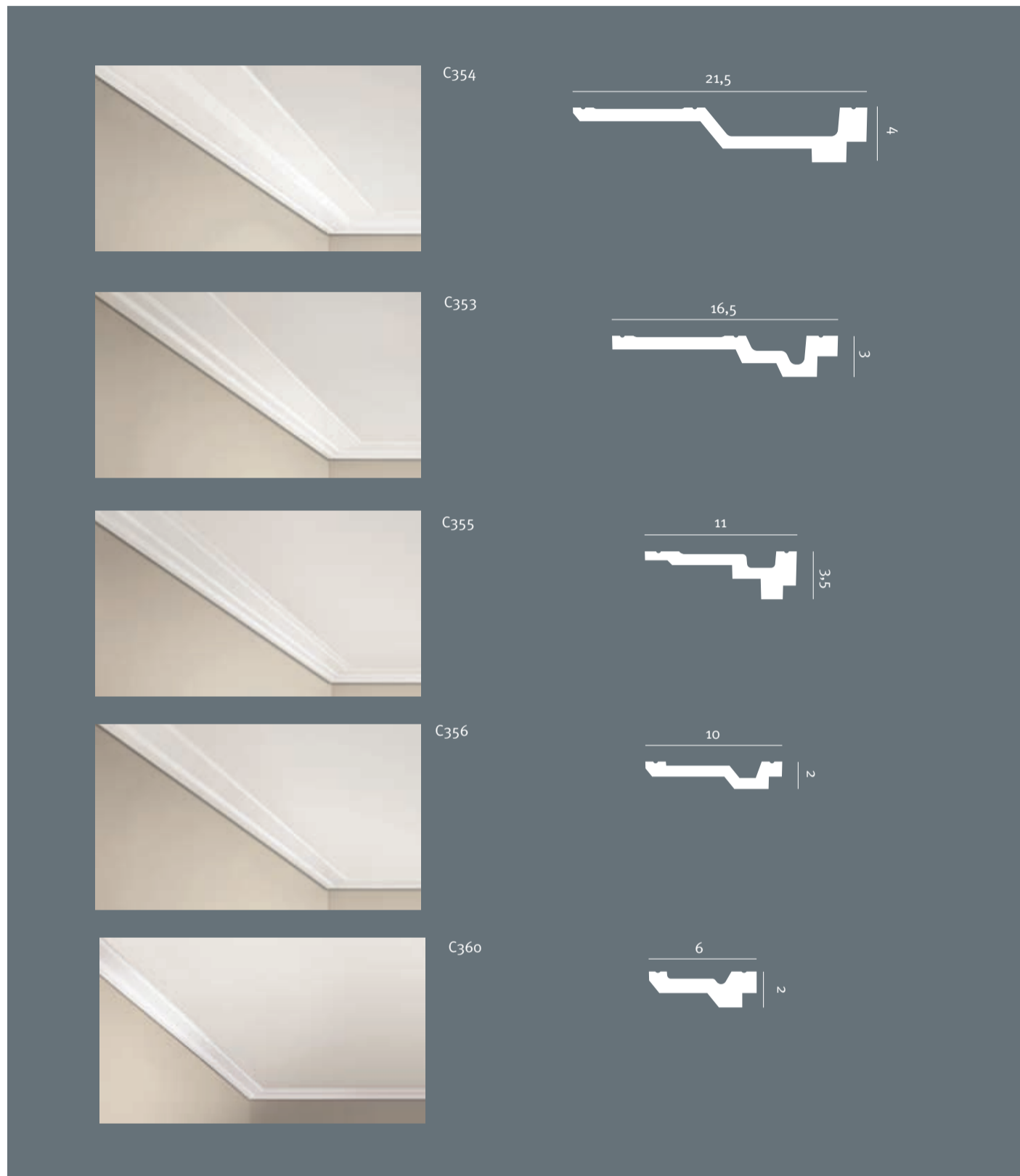

DIMENSIONS IN CM



Use DecoFix Pro & DecoFix Extra for perfect installation and warranty



DecoFix Pro can be sanded after hardening



Integrated V-fix for easy glueing



Easy to finish with a quality paint; UV-stable after final painting



Remove DecoFix Pro & DecoFix Extra before hardening

PRODUCT FOCUS

SKIRTING PLINTEN PLINTHES SOCKELLEISTEN

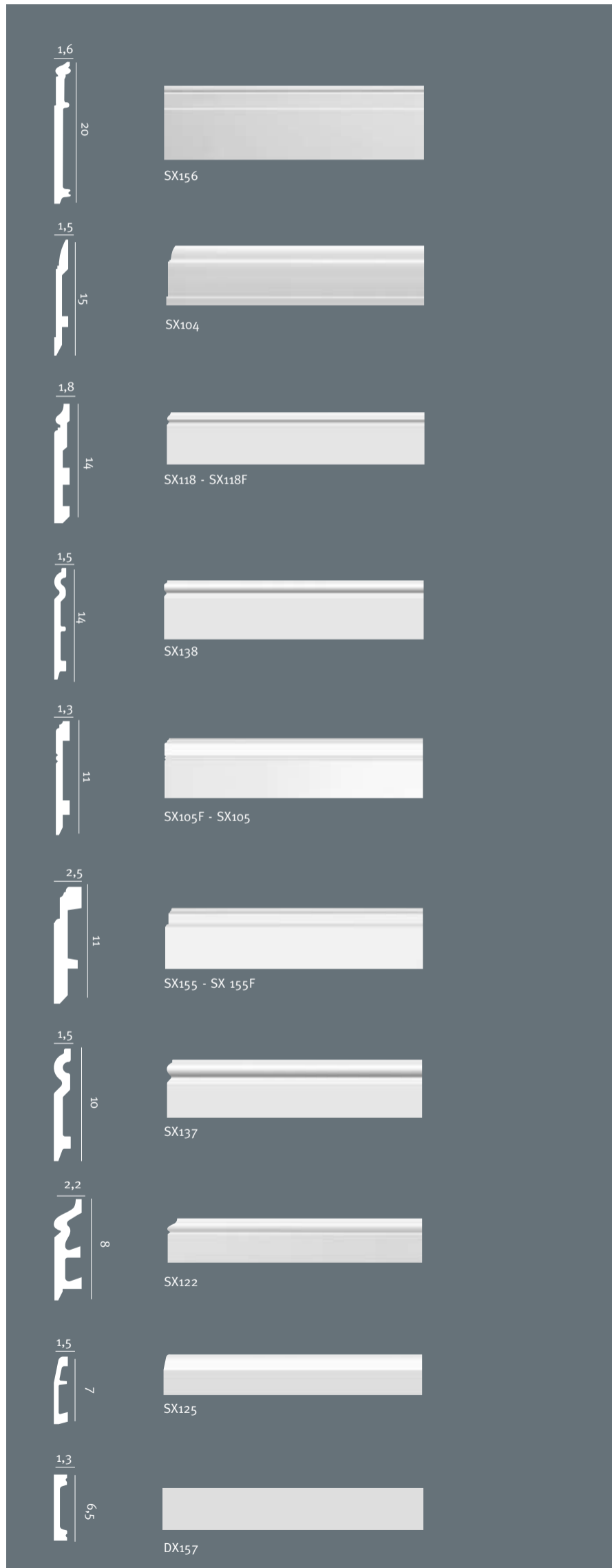

DIMENSIONS IN CM



Use DecoFix Pro & DecoFix Extra for perfect installation and warranty



Primed products, for a smooth and matt surface and enhanced paint adhesion



Easy to finish with a quality paint; UV-stable after final painting



Shock resistant



Resistant to most common solvents and moisture



Possibility to hide cables



LED-lighting available via Orac Decor

PRODUCT FOCUS

INDIRECT

LIGHTING VERLICHTING BELEUCHTUNG ECLAIRAGE

	C351	
	C352	
	C358	
	C357	
	C900	
	C901	
	C902	

DIMENSIONS IN CM



Available Orac Decor Lighting Systems

	ORAC T5 Tube		ORAC Light Plate	
Reference	IL002-001	IL002-002	IL001-005	IL001-006
Length	59 cm	119 cm	55 cm	223 cm
Voltage	230 VA	230 VAC	230 VAC	230 VAC
Lamps	T5 HE lamps included		T5 lamps not included	
Watt/fixture	14W	28W	14W	2 x 28W
Life time lamps	15,000 hrs	15,000 hrs	15,000 hrs	15,000 hrs
Max n° Connected	12 pieces		30 pieces	
Dimmable	no		yes integrated digital dimmer: Philips Dali Touch&Dim	

HEIMTEXTIL

FRANKFURT – GERMANY – 13-16/01/2010 – 5.1 B48

MAISON ET OBJET

PARIS – FRANCE – 22-26/01/2010 – 5CA22

INTIRIO

GHENT – BELGIUM – 31/01-03/02/2010 – 8C01

FARBE

MÜNCHEN – GERMANY – 24-27/03/2010 – A6310

HOMEBUILDING & RENOVATING

NEC BIRMINGHAM – UK – 18-21/03/2010 – F55

ARCHITECT@WORK

ROTTERDAM – THE NETHERLANDS – 15-16/09/2010

CONSTRUTEC

MADRID – SPAIN – 28/09-01/10/2010

GRAND DESIGNS

LONDON – UK – 08-10/10/2010 – B174

SGA

GORINCHEM – THE NETHERLANDS – 26-28/10/2010

DECO & FINISH

ANTWERP – BELGIUM – 19-20/11/2010 – A100

NV ORAC SA

BIEKORFSTRAAT 32
8400 OSTEND, BELGIUM
T. +32 (0)59 80 32 52
F. +32 (0)59 80 28 10
INFO@ORACDECOR.COM

WWW.ORACDECOR.COM

ORAC[®]
DECOR